

FECHADORES PARA MOLDES DE FUNDICIÓN INYECTADA

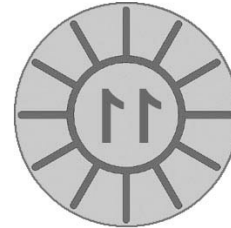
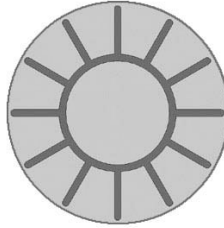
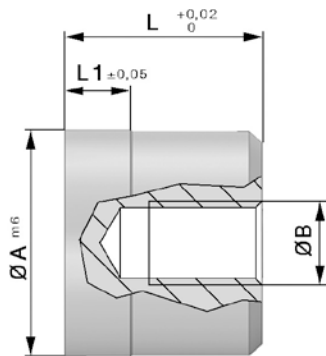

COD.	A	B	L	L1
DAP-5N	5	M3	10	4
DAP-6N	6	M4	10	4
DAP-8N	8	M4	10	4
DAP-10N	10	M5	12	5
DAP-12N	12	M6	14	5
DAP-16N	16	M6	14	6
DAP-20N	20	M6	16	6

MAT.: AISI 420 46+48 HRC

COD.	A	B	L	L1
DAP-5A	5	M3	10	4
DAP-6A	6	M4	10	4
DAP-8A	8	M4	10	4
DAP-10A	10	M5	12	5
DAP-12A	12	M6	14	5
DAP-16A	16	M6	14	6
DAP-20A	20	M6	16	6

MAT.: AISI 420 46+48 HRC

ELECTRODOS PARA EL RECICLAJE



FIGURA COMO MODELO
STANDARD

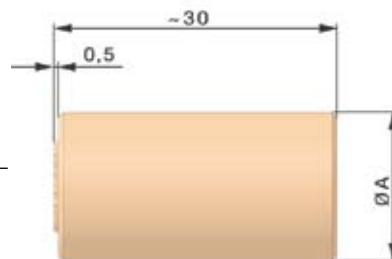

COD.	A	S
ER-6	6	4
ER-8	8	5
ER-10	10	6
ER-12	12	8
ER-16	16	10
ER-20	20	12

BAJO DEMANDA SE REALIZAN ELECTRODOS E INSERTOS RECICALJE CON GRABADOS ESPECIALES (INCISIÓN LÁSER).